



USER GUIDE



ULTIMATE VR GUN

MADE BY 3D HORIZONS

INBOX CONTENT



BOLT x2



NUT x2

TACTICAL STOCK

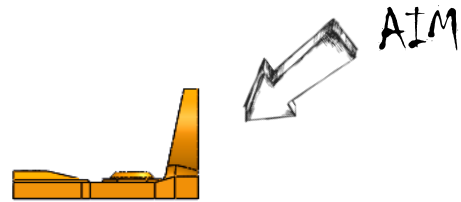
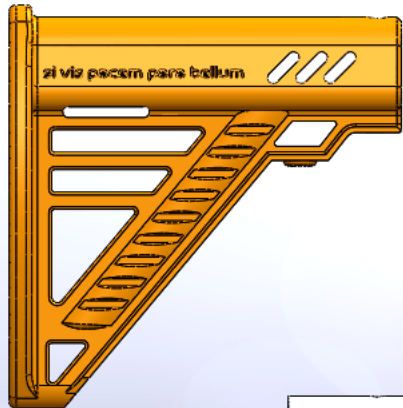

AIM

MOUTHPIECE

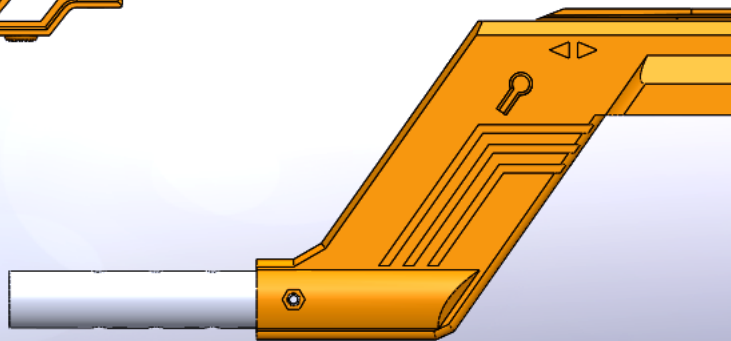
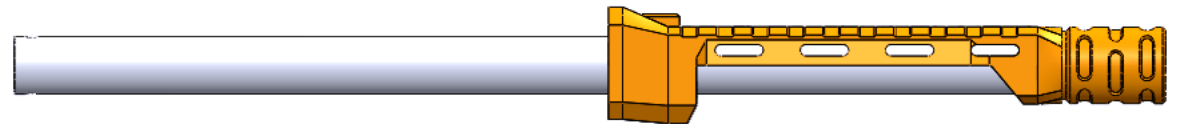

MAIN BODY

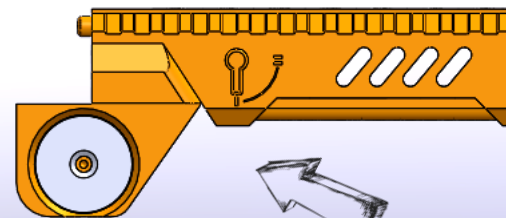
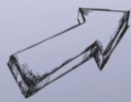

INTERMEDIATE BODY



ADAPTATOR #1

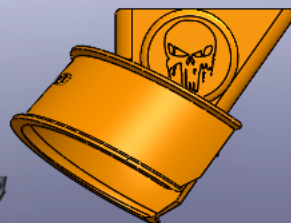
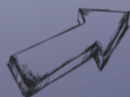

ADAPTATOR #2

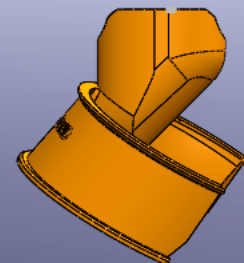
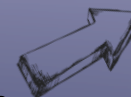



WARNING BEFORE USE



The inside of the tubes can be sharp.

DON'T PUT YOUR FINGER INSIDE.

Don't worry, it won't be accessible once mounted ;)

ATTENTION

ATTENTION

The ULTIMATE VR GUN contains strong magnets. Thank you for reading these recommendations.



Responsability – 3D HORIZONS will not endorse any responsibility for any damage which could happen from using the magnets incorrectly. You must read, understand and take into account these warnings.

The ULTIMATE VR GUN is delivered with magnets already assembled for your safety. Don't remove them.

Pinching – The neodyme magnets, even small in size, are strong enough to pinch a finger.

Don't put the magnets near the nose or ears.

Magnetic sensitive objects – Keep a minimum security distance (2 inches minimum) between the magnets and any objects which could be affected by magnetism like your VR headset, credit cards, or magnetic storages.

Cardio stimulators – Keep the magnets away from heart stimulators. Immediate proximity from a magnet to a heart stimulator would affect its functioning, wich could be harmful for the user.

Allergy : Neodyme magnets are covered with nickel. If you have an allergy with nickel, you should avoid extended contact on your skin.



Danger for children – These magnets must not be manipulated by children under the age of 12 years old. If one or more magnets are swallowed, they could attract each other through stomach wall, causing life threatening danger and the need of surgical intervention.

Step 1

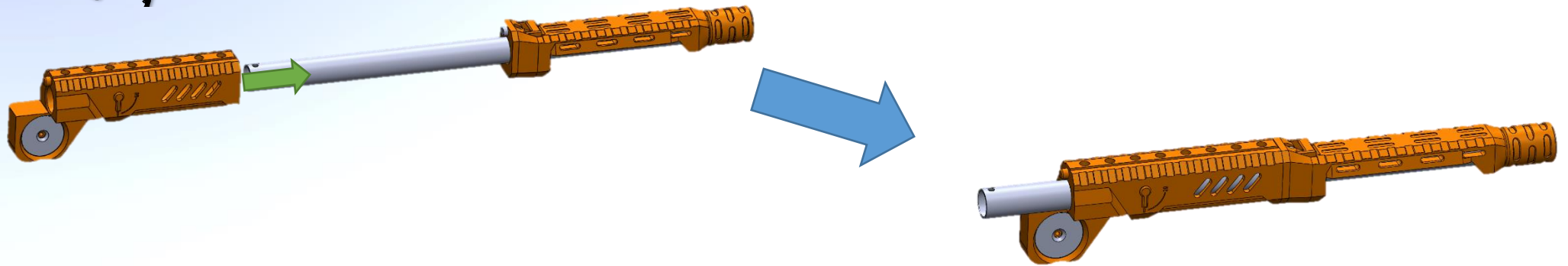

Step 2

For this step, you will need an hexagonal key.

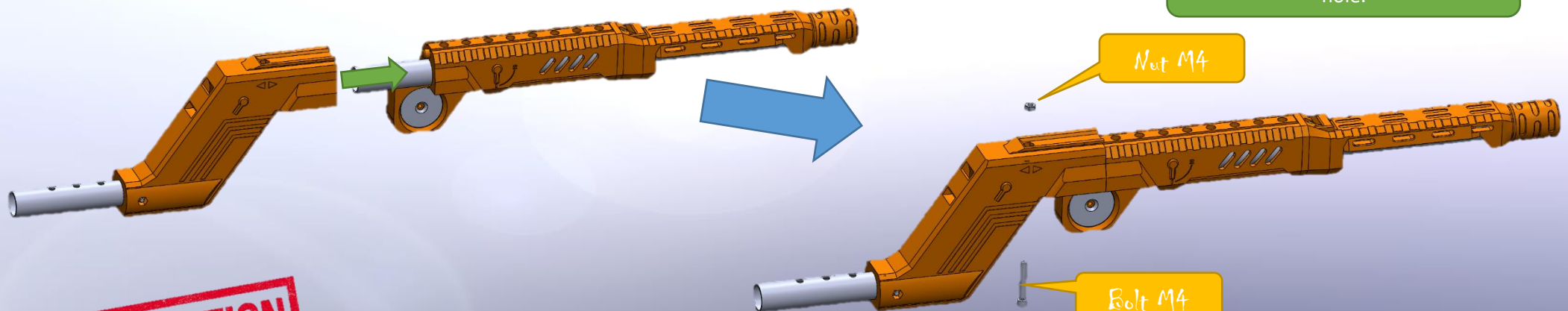

Insert the nut in the hexagonal hole.

Nut M4

Bolt M4

Insert the bolt through the hole then assemble.

ATTENTION

Anti loosening Nylock bolt.

You will need a slight force to screw, but not too strong, be careful not to deform the tube.

Step 3

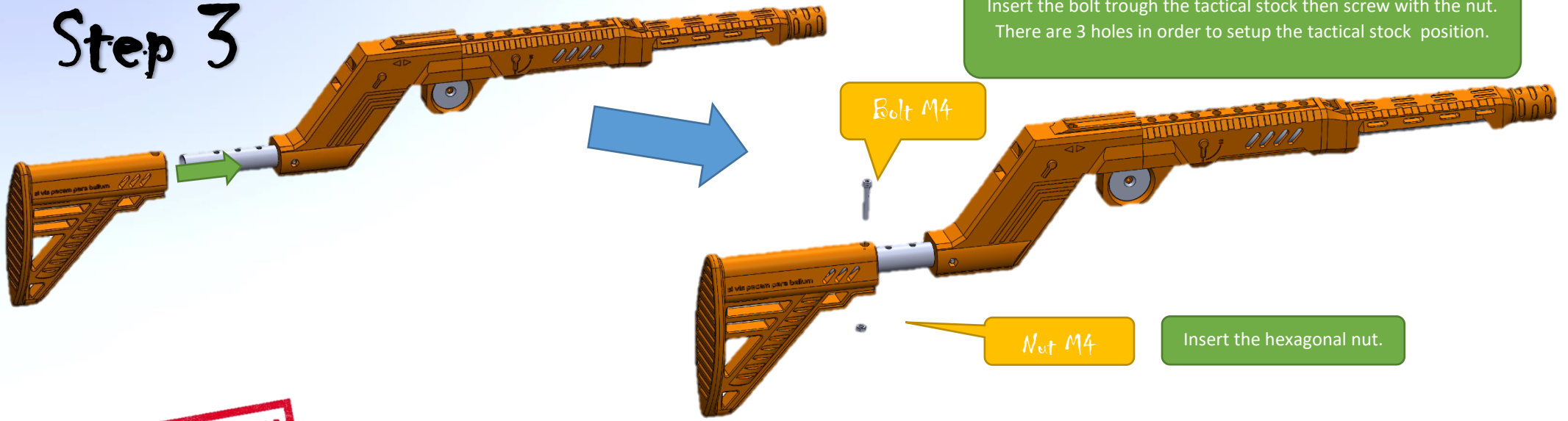

ATTENTION

If you don't intend to keep the aim in place, there is no need to force while mounting. As 3D impression doesn't like slidings.

The aim could be problematic when reloading in games. It is advised that you should put it off when playing, and on when you don't use the ULTIMATE VR GUN.

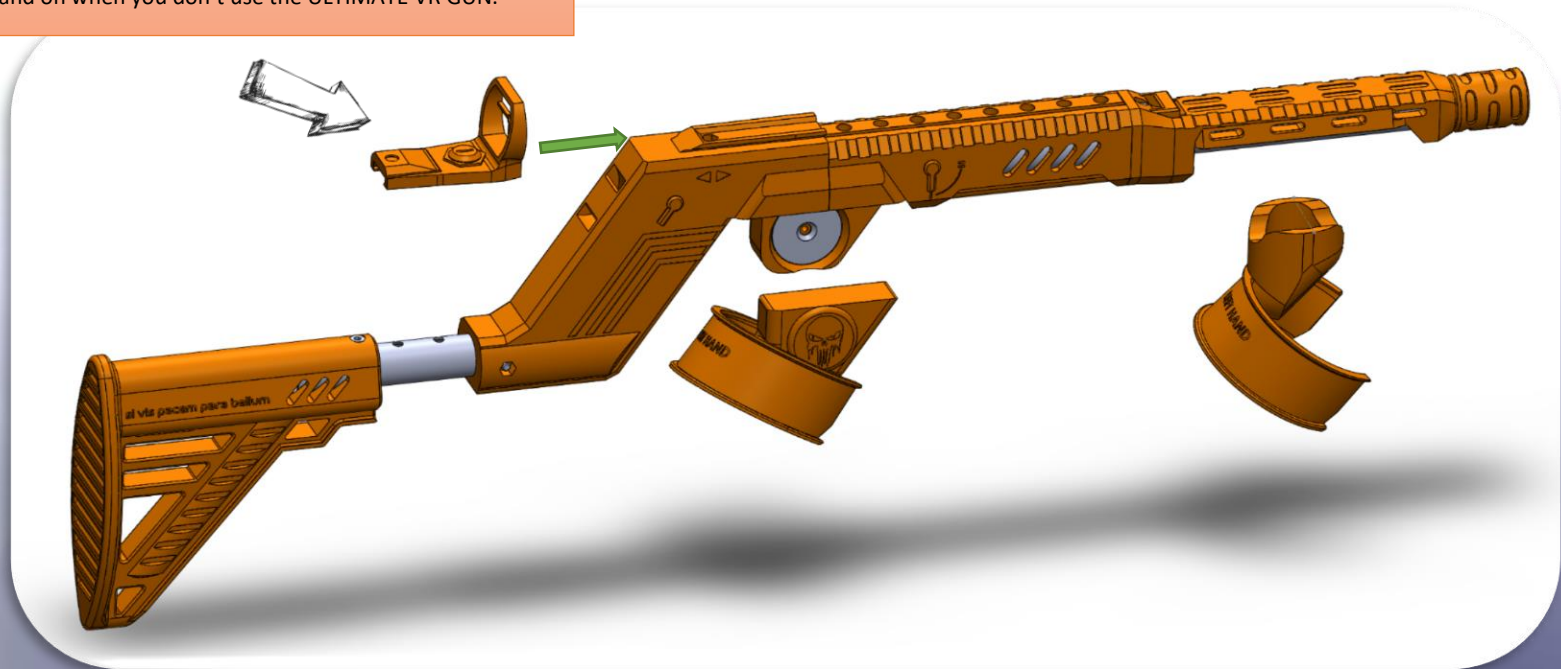

ADVICE OF USE

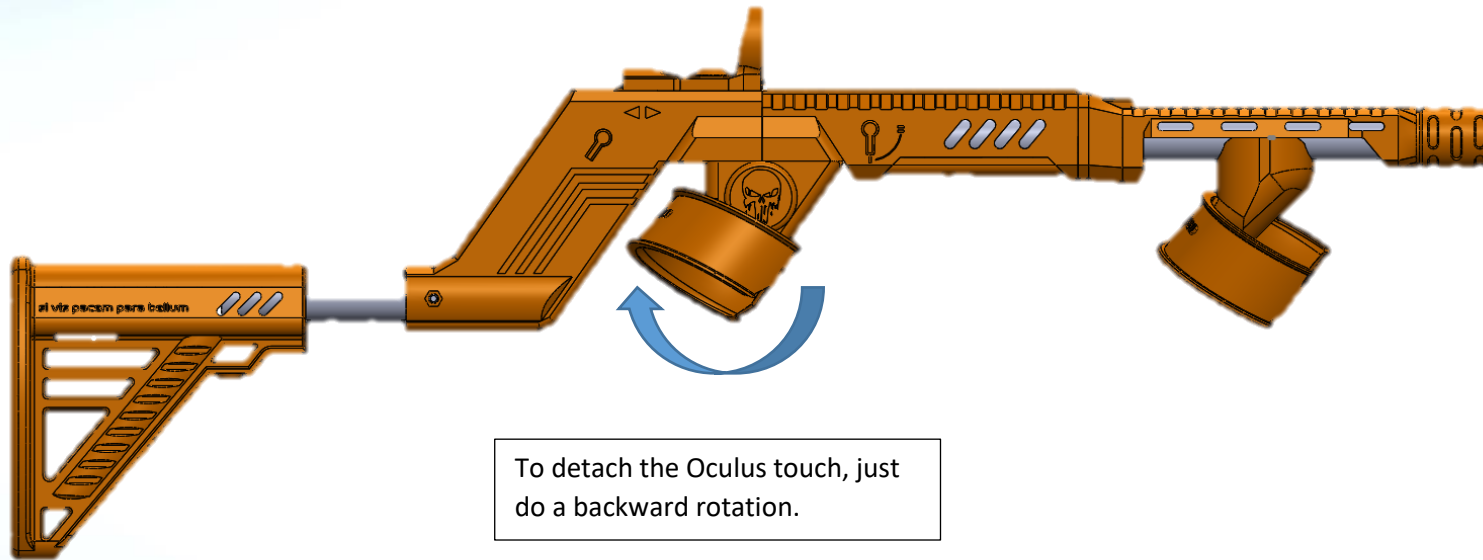

To detach the Oculus touch, just do a backward rotation.

ATTENTION

Manipulate the ULTIMATE VR GUN with precautions.

Be sure to have a sufficient space around you to ensure that you can manipulate the oculus controllers without coming into contact with other objects.

3D Horizons society can not be considered as responsible for any damages caused on the Oculus touch controllers.